

R. Pourcelot^{a,b}, L. Pueyo^b, E. H. Por^c, M. D. Perrin^b, S. Steiger^b, R. Soummer^b, R. Telfer^b

Observing Earth-like exoplanets with require contrast levels of $\sim 10^{-10}$ over extended integration time. This requires unprecedented observatory stability (picometric for some mode).

The Habitable Worlds Observatory will require:

- A very stable structure
- An active coronagraph

⇒ How far is current technology?

Example architecture "EAC 1" studied for HWO¹



Current technologies

- JWST:
 - Very stable
 - But static / older coronagraph
- Roman Space Telescope-style coronagraph:
 - apodizer + focal plane mask + Lyot stop
 - 2 DMs control

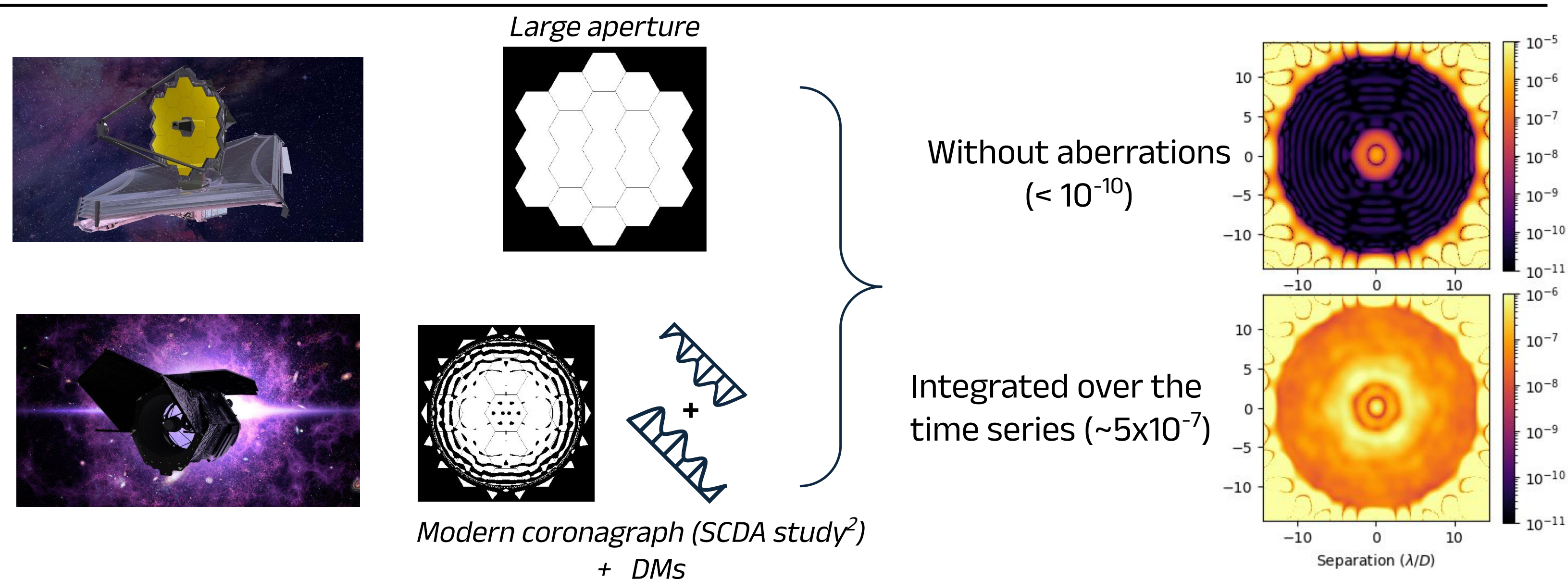

Simulated implementation (using CATkit2³):

- Two versions of Zernike Wavefront sensors
- Correction with primary (segmented) mirror vs. correction with continuous deformable mirror (DM)

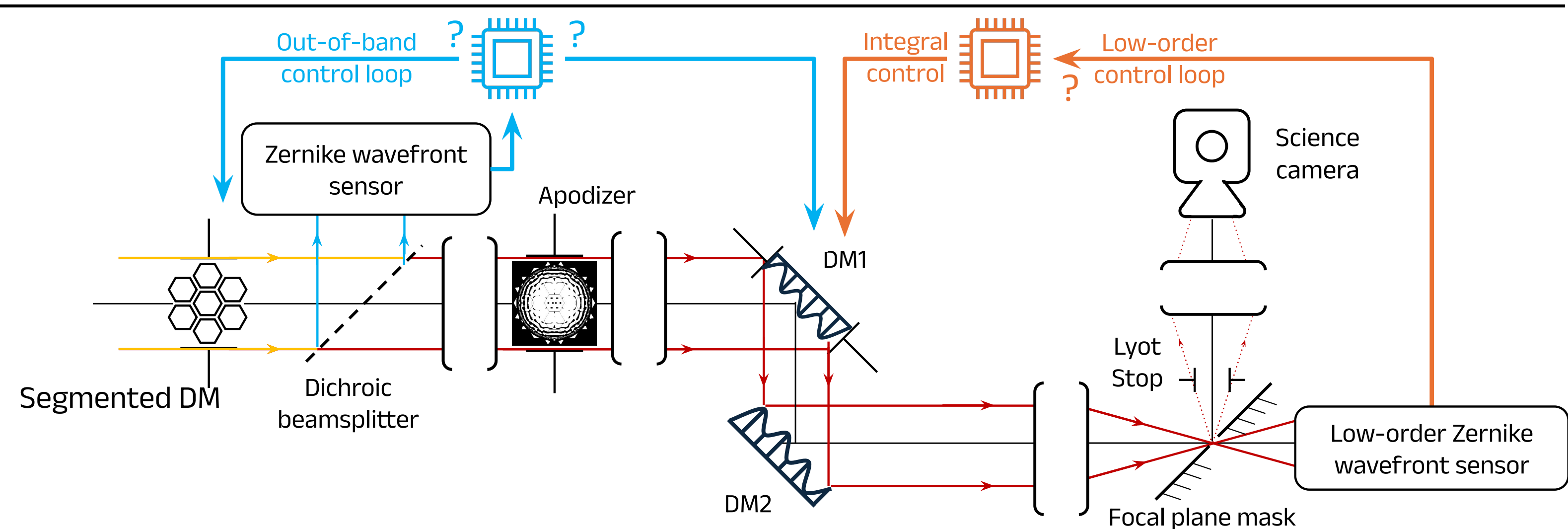

The method, inspired from⁵, consists in combining:

- JWST in-flight data
- Plugging it into analytical simulations of an active coronagraph

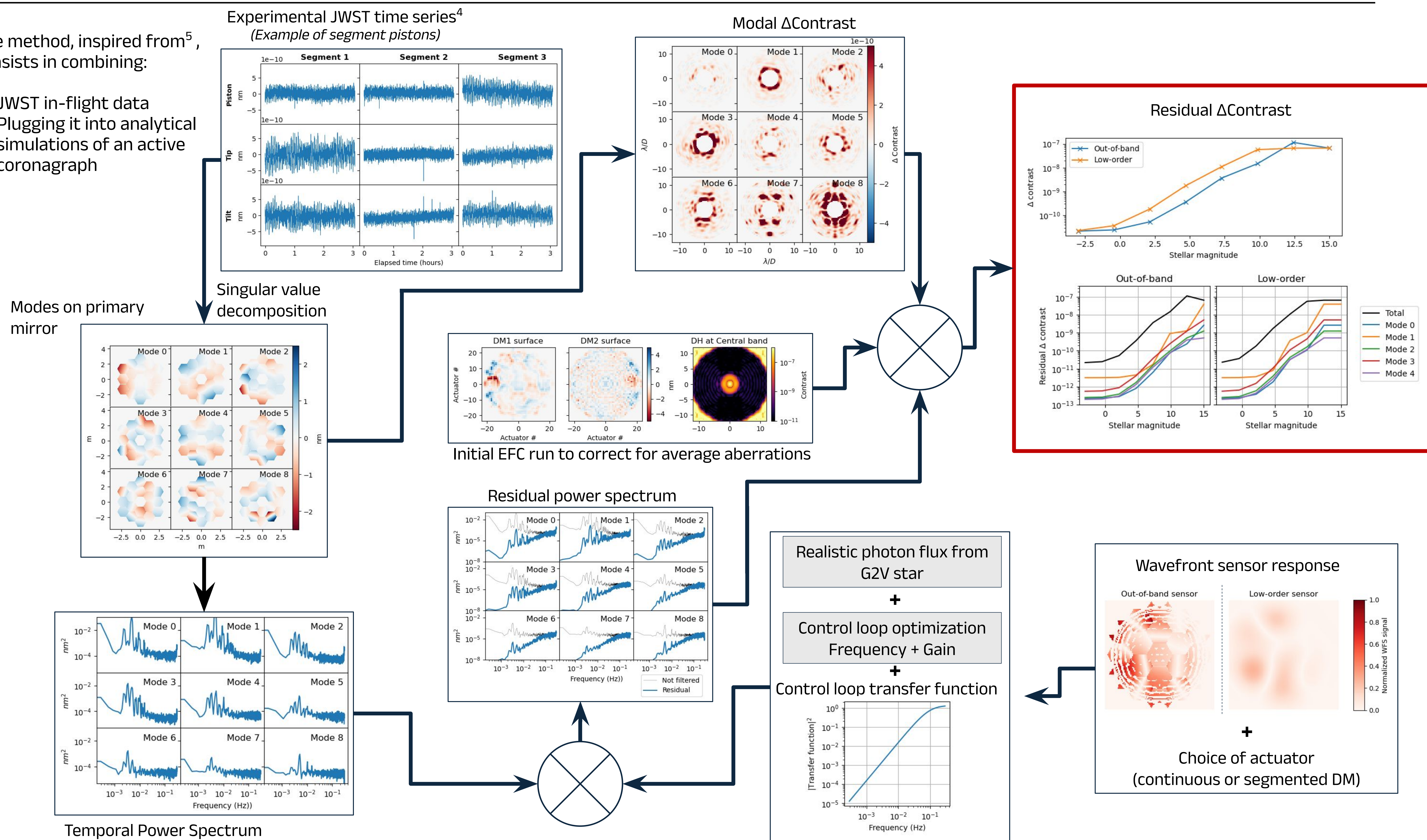

Affiliations

^aMax Planck Institute for Astronomy, ^bSpace Telescope Science Institute, ^cUniversity of California in Santa Cruz

References:

¹Feinberg et al., ArXiv, 2026
²Nickson et al., SPIE, 2022

³Por et al., Github / Zenodo

⁴Telfer et al., SPIE, 2024

⁵Potier et al., JATIS, 2022